



**HAMILTON
LABORATORY
GLASS
LIMITED**

WATER STILL INSTRUCTIONS

Unit A1 Continental Approach, Westwood Industrial Estate,
Margate, Kent CT9 4JG
Telephone: 01843 232633
Facsimile: 01843 232644
E-mail: sales@hamiltonlabglass.com



PLEASE READ VERY IMPORTANT

On our 8 litre versions of our water still they have had an electrical revamp,

1. When fitting the silica heaters you can lay the panel on its side giving you an improved access to the terminals.
2. The terminal blocks which have orange levers are very easy to use and they are just a push down action which will open the clamp, when you release the lever it closes.
3. The big grey terminal blocks are very easy to use and very secure; we have supplied a diagram which is attached to show you how to use them.
4. The heater terminals have been renamed and these have been high lighted on the diagram provided which is attached. **Please refer to this rather than the book.**

All of the above is mainly for the silica versions of our waterstill, as the metal heater versions the heaters are already fitted for you.

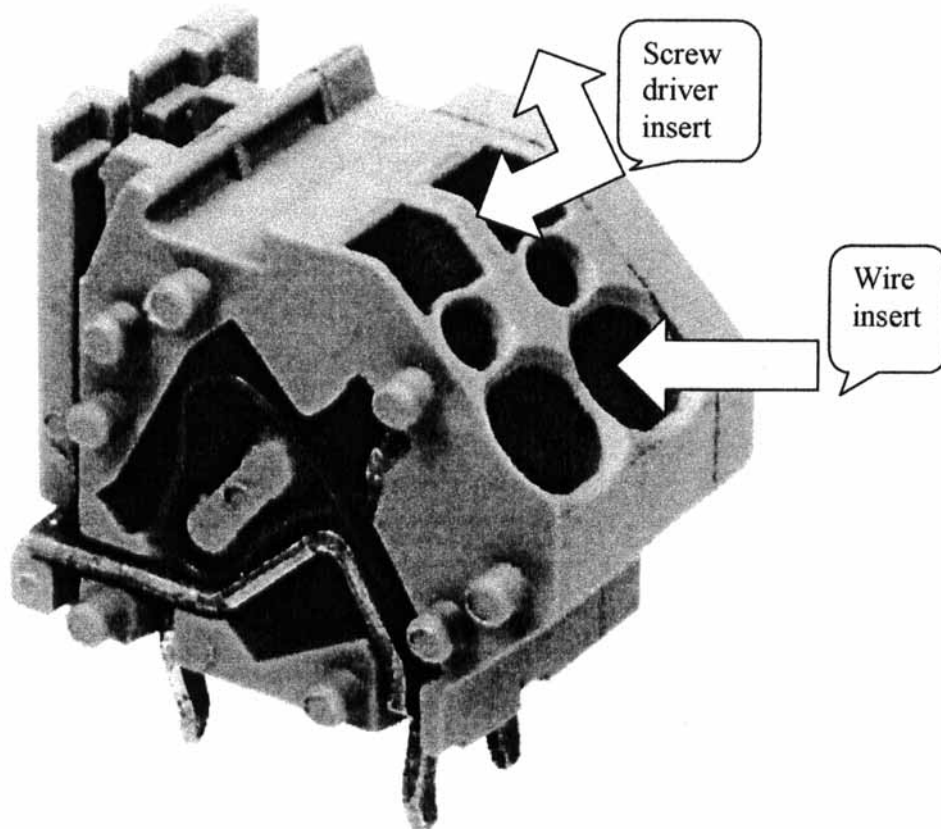

Diagram of new Connector

The new connector is very easy to use, where it says screw driver insert please use a slot headed 2.5 X 75 screw driver which will fit perfectly. When done so lever the screw driver upwards and this will open the clamp inside, holding the screw driver there please insert the wire as labeled on the diagram above. When done so pull screw driver out creating a tight fitment

Dear Customer

Thank you for buying Hamilton water still. We suggest you record the model number and serial number for future reference. PLEASE READ THE INSTRUCTIONS. At no time should the heaters be turned on until covered with water unless stated to do so.

Contents

	Page No.
Fitment of Heaters	4
Internal Piping for all 4 & 8 litre Models	5
External Piping for all Stills	5
Internal Piping for Double Distilled Models	6
Getting Started	
WSC/4 - WSC/4S	7
WSC/8 - WSC/8S	8
AWC/4 - AWC/4S	9
AWC/8 - AWC/AS	10
AWC/4D	11
WSC/4D	12
WSB/4	13
WSE/4S	14
Diagrams for WSB/4 and WSE/4S	15
RS/25 Fitting Instructions	16 - 18
WSS/4 - WSS/8	19
Deionisers	20
Troubleshooting	21
Spares List	24
Recommended cleaning instructions	back page
Diagrams	
Heaters	4
Horizontal Condensers	5 - 6
WSE/4S - WSB/4	15
8 Litre Model Circuit Board	22
4 Litre Model Circuit Board	23

Metal heaters

Please note, if you have ordered a WSC/4, WSC/8, AWC/4 OR AWC/8 the metal heaters have already been fitted for you

Silica Heaters you should have

WSC/4S , AWC/4S

1 UNIT = 2 x 1.5

WSC/8S, AWC/8S

UNIT 1 = 2 x 1.5 UNIT 2 = 2 x 1.5

WSC/4D, AWC/4D

UNIT 1 = 2 x 1.5 UNIT 2 = 1 X 1.5 / 1 X 1.25

Fitting the Silica heaters

1. Remove the electrical panel from the cabinet by releasing the two screws on the top side of the cabinet.
2. Place the silica heaters into the boiling chambers matching up the corresponding numbers on the cabinet and the heating elements, Tighten screw caps to secure heaters.
3. Refer to electrical diagram and connect electrical cable to the relevant connections N (blue) and L (brown) matching the corresponding numbers. Replace electrical panel and secure.

Diagram for heaters

VERY IMPORTANT

ON NO ACCOUNT SWITCH ON THE STILL BEFORE THE WATER HAS COVERED THE HEATER

Assembly - Silica Heater

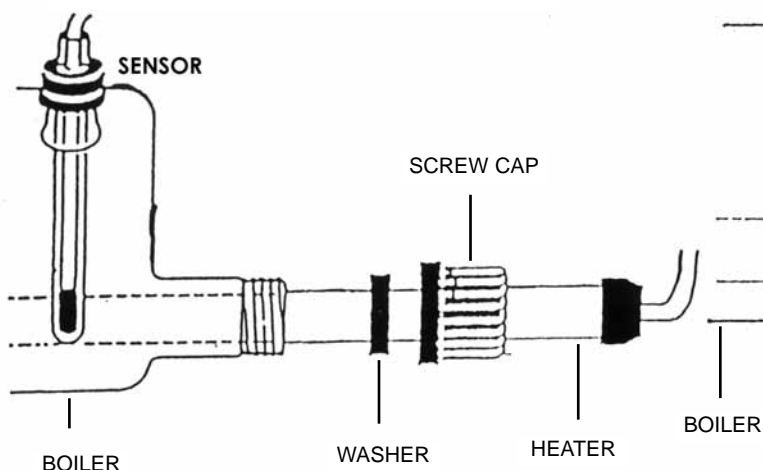

Assembly - Metal Heater

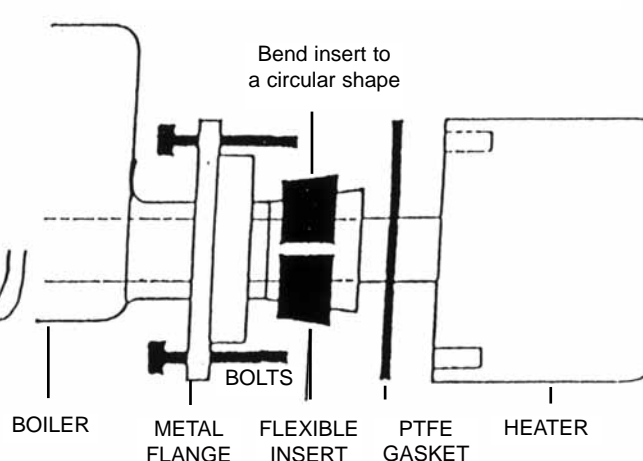

INTERNAL PIPING 8 LITRES Standard and Aquamatic

Hint: Pipe all of unit 1 before unit 2

(Except deioniser stills)

Metal and Silica

Please look at diagram below

Unit 1 Condenser

1. Supply to nozzle 1
2. Float switch to nozzle 2
3. Output to nozzle 3

Unit 2 Condenser

1. Supply to nozzle 1
2. Float switch to nozzle 2
3. Output to nozzle 3

INTERNAL PIPING 4 LITRES Standard and Aquamatic

Metal and Silica

Please look at diagram below

Condenser

1. Supply to nozzle 1
2. Float switch to nozzle 2
3. Output to nozzle 3

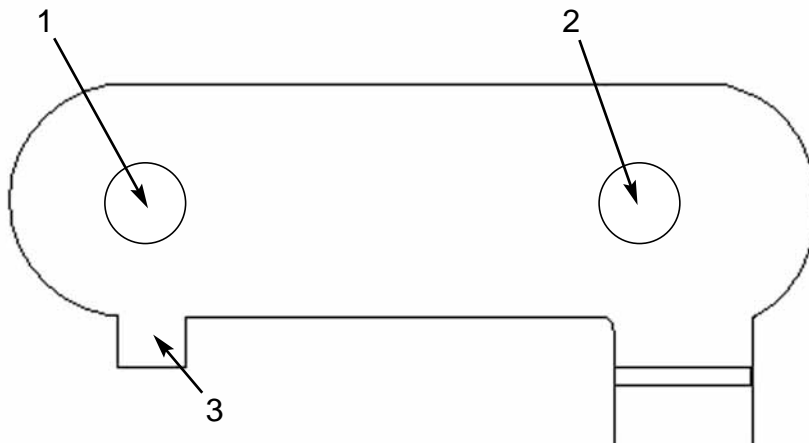

Horizontal condenser

EXTERNAL PIPING for all stills (Except deioniser stills)

- Connect the water supply marked (SUPPLY). The connections from the mains must be secure.
- Connect hose from OUTLET to Reservoir.
- Connect hose from WASTE to external Drainage area

Double distilled models ie AWC/4D AND WSC/4D

Please refer to diagram of horizontal condenser

Hint: Pipe all of unit 1 before unit 2

UNIT 1

1. Supply to nozzle 1
2. Float switch to nozzle 2
3. Pipe attached to condenser to be placed inside constant level on boiling chamber 2

UNIT 2

1. Supply to nozzle 1
2. Float switch to nozzle 2
3. Output to nozzle 3

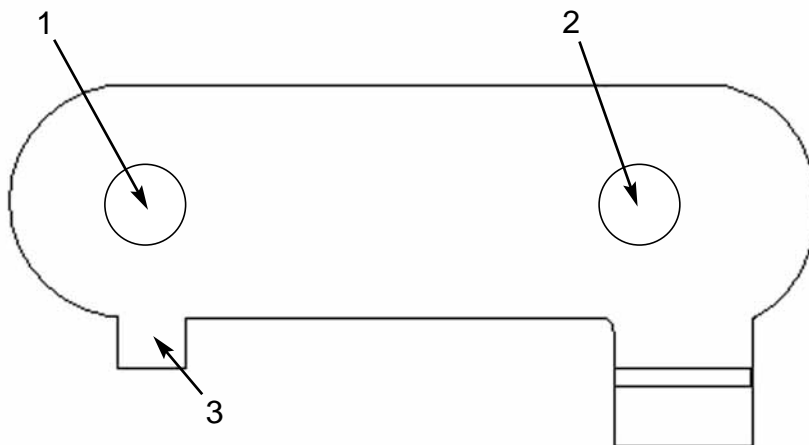

Horizontal condenser

WSC/4, WSC/4s

Getting Started

Please refer to INTERNAL PIPING AND EXTERNAL PIPING BEFORE THE FOLLOWING

At no time should the electricity supply be turned on until the heating element is completely covered by water.

Please note that the heaters have already been fitted for you on model WSC/4, For the WSC/4S please refer to fitting instructions for silica heaters.

- Turn the water supply gently, which will circulate through the Condenser into the float switch, then into the boiling chamber, allowing the water to cover the heaters.
- When the heaters are covered switch on the unit.
- When the unit is running it may be necessary to adjust the water supply to give minimum waste and maximum output by controlling the water supply in the float switch to the red line.
- The unique flow control unit allows the water supply to be set visually at the correct volume input. This reduces to the minimum amount of water going to waste, at the same time giving the best setting for the maximum output of distillation.
- There is a sensor inside the unit this will automatically switch off the unit if overheating reaches a critical point.

WSC/8 , WSC/8s

Getting Started

Please refer to INTERNAL PIPING AND EXTERNAL PIPING BEFORE THE FOLLOWING

At no time should the electricity supply be turned on until the heating element is completely covered by water.

Please note that the heaters have already been fitted for you on model WSC/8, For the WSC/8S please refer to fitting instructions for silica heaters.

- Turn the water supply on gently, which will circulate through the Condensers into the float switch, then into the boiling chambers, allowing the water to cover the heaters.
- When the heaters are covered switch on the unit then Unit 1 and Unit 2.
- When the unit is running it may be necessary to adjust the water supply to give minimum waste and maximum output by controlling the water supply in the float switch to the red line.
- The unique flow control unit allows the water supply to be set visually at the correct volume input. This reduces to the minimum amount of water going to waste, at the same time giving the best setting for the maximum output of distillation.
- There are two sensors, one for each unit; these will automatically switch off the unit if overheating reaches a critical point.

AWC/4, AWC/4S

Getting started

Please refer to **INTERNAL PIPING AND EXTERNAL PIPING BEFORE THE FOLLOWING**

At no time should the electricity supply be turned on until stated

Please note that the heaters have already been fitted for you on model AWC/4, For the AWC/4S please refer to fitting instructions for silica heaters.

- Turn on water supply slowly. **Switch on the mains and turn on the Boiling fill/cleanse button**, which will circulate through the Condenser into the float switch, then into the boiling chamber, allowing the water to cover the heaters.
- When the heaters are covered switch on the unit
- When the unit is running it may be necessary to adjust the water supply to give minimum waste and maximum output by controlling the water supply in the float switch to the red line.
- The unique flow control unit allows the water supply to be set visually at the correct volume input. This reduces to the minimum amount of water going to waste, at the same time giving the best setting for the maximum output of distillation.
- There is a sensor inside the unit this will automatically switch off the unit if overheating reaches a critical point.
- The RES full light will come on when the required level of distillate is reached; this will shut off the electrics to the heaters. To restart turn off and wait 5 Seconds and turn back on.
- Connect a hose to nozzle marked PS to the reservoir. This will automatically shut off the electrics to the heaters when the required level of distillate is reached.

AWC/8, AWC/8S

Getting started

Please refer to **INTERNAL PIPING AND EXTERNAL PIPING BEFORE THE FOLLOWING**

At no time should the electricity supply be turned on until stated

Please note that the heaters have already been fitted for you on model AWC/8, For the AWC/8S please refer to fitting instructions for silica heaters.

- Turn on water supply slowly. **Switch on the mains and turn on the Boiling fill/cleanse button**, which will circulate through the Condensers into the float switch, then into the boiling chambers, allowing the water to cover the heaters.
- When the heaters are covered switch on the unit then Unit 1 and Unit 2.
- When the unit is running it may be necessary to adjust the water supply to give minimum waste and maximum output by controlling the water supply in the float switch to the red line.
- The unique flow control unit allows the water supply to be set visually at the correct volume input. This reduces to the minimum amount of water going to waste, at the same time giving the best setting for the maximum output of distillation.
- (AWC/8S ONLY) There are two sensors, one for each unit; these will automatically switch off the unit if overheating reaches a critical point.
- The RES full light will come on when the required level of distillate is reached; this will shut off the electrics to the heaters. To restart turn off and wait 5 Seconds and turn back on.
- Connect a hose to nozzle marked PS to the reservoir. This will automatically shut off the electrics to the heaters when the required level of distillate is reached.

AWC/4D

Getting started

Please refer to INTERNAL PIPING AND EXTERNAL PIPING BEFORE THE FOLLOWING

**At no time should the electricity supply be turned on until stated
For the AWC/4D please refer to fitting instructions for silica heaters.**

- Turn on water supply slowly. Switch on the mains and turn on the Boiling fill/cleanse button. , which will circulate through Unit 1's Condenser into the float switch, then into the boiling chamber, allowing the water to cover the heaters.
- When the heaters are covered switch on Unit 1, Not Unit 2.
- When Unit 2 has filled with the distilled water from Unit 1 and has covered the heaters then you may turn on Unit 2's heaters
- When the unit is running it may be necessary to adjust the water supply to give minimum waste and maximum output by controlling the water supply in the float switch to the red line.
- The unique flow control unit allows the water supply to be set visually at the correct volume input. This reduces to the minimum amount of water going to waste, at the same time giving the best setting for the maximum output of distillation.
- There are two sensors, one for each unit; these will automatically switch off the unit if overheating reaches a critical point.
- The RES full light will come on when the required level of distillate is reached; this will shut off the electrics to the heaters. To restart turn off and wait 5 Seconds and turn back on.
- Connect a hose to nozzle marked PS to the reservoir. This will automatically shut off the electrics to the heaters when the required level of distillate is reached.

WSC/4D

Getting started

Please refer to INTERNAL PIPING AND EXTERNAL PIPING BEFORE THE FOLLOWING

At no time should the electricity supply be turned on until the heating element is completely covered by water.

For the WSC/4D please refer to fitting instructions for silica heaters.

- Turn on water supply slowly, which will circulate through Unit 1's Condenser into the float switch, then into the boiling chamber, allowing the water to cover the heaters.
- When the heaters are covered switch on the unit and turn on Unit 1, Not Unit 2.
- When Unit 2 has filled with the distilled water from Unit 1 and has covered the heaters then you may turn on Unit 2's heaters
- When the unit is running it may be necessary to adjust the water supply to give minimum waste and maximum output by controlling the water supply in the float switch to the red line.
- The unique flow control unit allows the water supply to be set visually at the correct volume input. This reduces to the minimum amount of water going to waste, at the same time giving the best setting for the maximum output of distillation.

WSB/4

At no time should the electricity supply be turned on until the heating Element is completely covered.

Please refer to diagram below to follow the instructions.

Getting started

- Place Part 1 to Part 2
Carefully place the condenser on top of the boiling chamber.
- Fit part 3 to part 2 by unscrewing the cap and fitting to the constant level to the boiling chamber.
- Connect the water supply to the bottom of the condenser and from the top of the condenser to the constant level
- Connect plastic tube to the constant level device on the boiling chamber and run to drain
- Connect plastic tube to distillate outlet at the bottom of the condenser and into reservoir
- Turn water supply on gently which will circulate through the condenser and into the boiling chamber, allowing the water to cover the heater.
- Turn on power supply when the heater is fully covered by the water.
- When the still is running it will be necessary to adjust the water supply to give minimum waste and maximum output.

See Diagram on page 15

WSE/4S

At no time should the electricity supply be turned on until the heating Element is completely covered.

Please refer to diagram below to follow the instructions.

Getting started

- Place part 1 to part 2 by carefully placing the condenser on top of the boiling chamber.
- Fit part 3 to part 2 by unscrewing the cap and fitting to the constant level to the boiling chamber.
- Connect the water supply to the bottom of the condenser and from the top of the condenser to the constant level
- Connect plastic tube to the constant level device on the boiling chamber and run to drain
- Connect plastic tube to distillate outlet at the bottom of the condenser and into reservoir
- Place part 5 to part 2 by unscrewing the caps and fitting the silica heaters into the boiling chamber and plug into the cabinet.
- Put together Part 4 by unscrewing the cap and fitting the sensor holder to the boiling chamber and threading the sensor into the holder. This will automatically switch off the unit if overheating reaches a critical point.
- Connect a hose to nozzle marked PS to the reservoir. This will automatically shut off the electrics to the heaters when the required level of distillate is reached.
- Turn water supply on gently which will circulate through the condenser and into the boiling chamber, allowing the water to cover the heater with a minimum amount of water to waste.
- The RES full light will come on when the required level of distillate is reached; this will shut off the electrics to the heaters. To restart turn off and wait 5 Seconds and turn back on.
- When the still is running it may be necessary to adjust the water supply to give minimum waste and maximum output.

Diagram of finished still on page 15

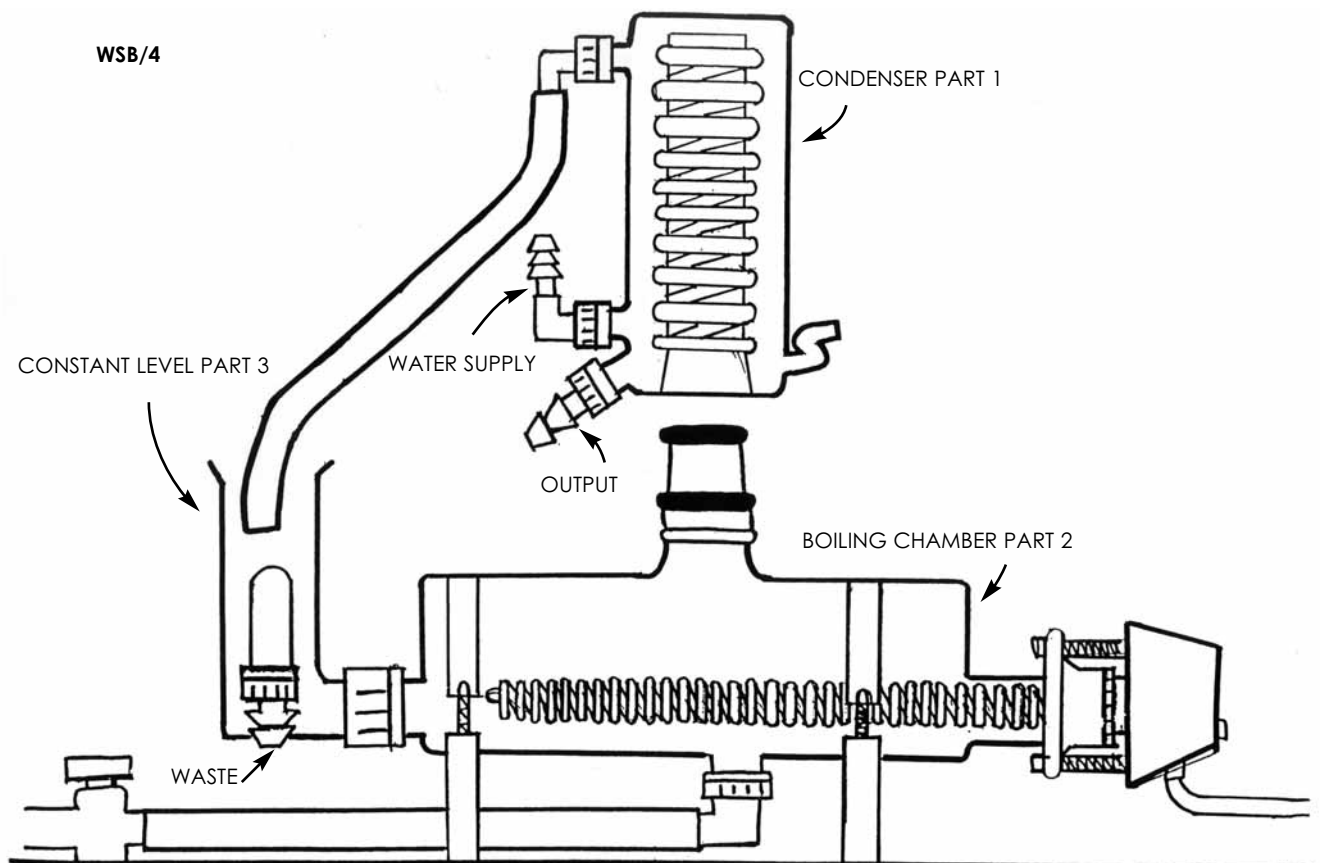
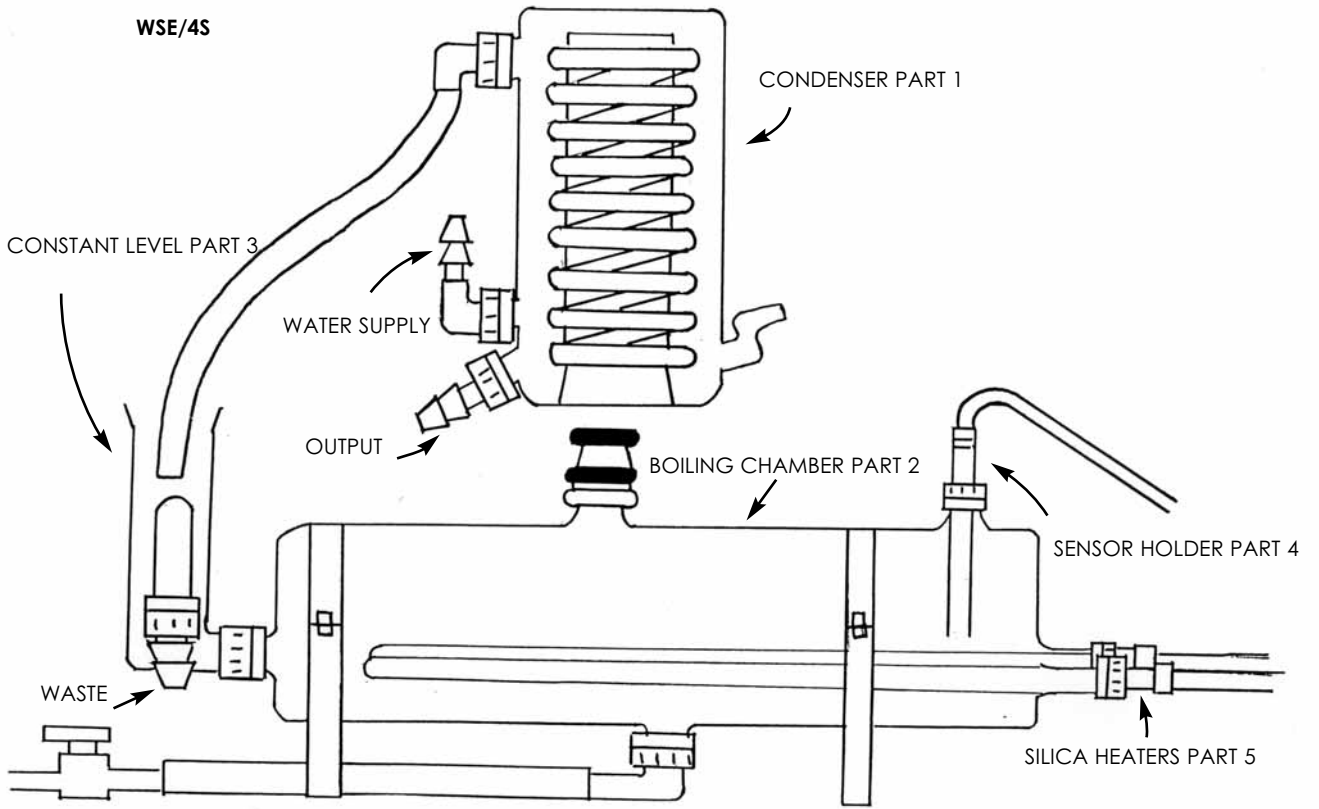

RS/25

If you have purchased a still with a reservoir already fitted please do not read the following as it does not apply to you, your cabinet has already be fitted and tested, all you have to do pipe the still according to the piping instructions i.e. WSC/4D

FITTING INSTRUCTIONS RS/25

These instructions apply to both 4 litre and 8 litre versions

When unwrapping the reservoir you will notice a bag of parts, in this bag you will find the following,

- 6 x bolts with nuts and washers
- 4 x rubber feet
- 2 x red connectors
- 4 x cable ties
- 1x tubing (1 foot)

Keep these safe as you will later need them.

First things first is to take the boilers and condensers out of the cabinet so the cabinet is completely empty, Please leave all the piping and float switch as this will not cause a problem and leave the electrical panel on for now. If the heaters have been fitted please take them out and put to one side. In each corner of the still you will notice a hole and also in the middle a long the edge.

These will line up with the holes on the reservoir. (please refer to diagram on page 16).

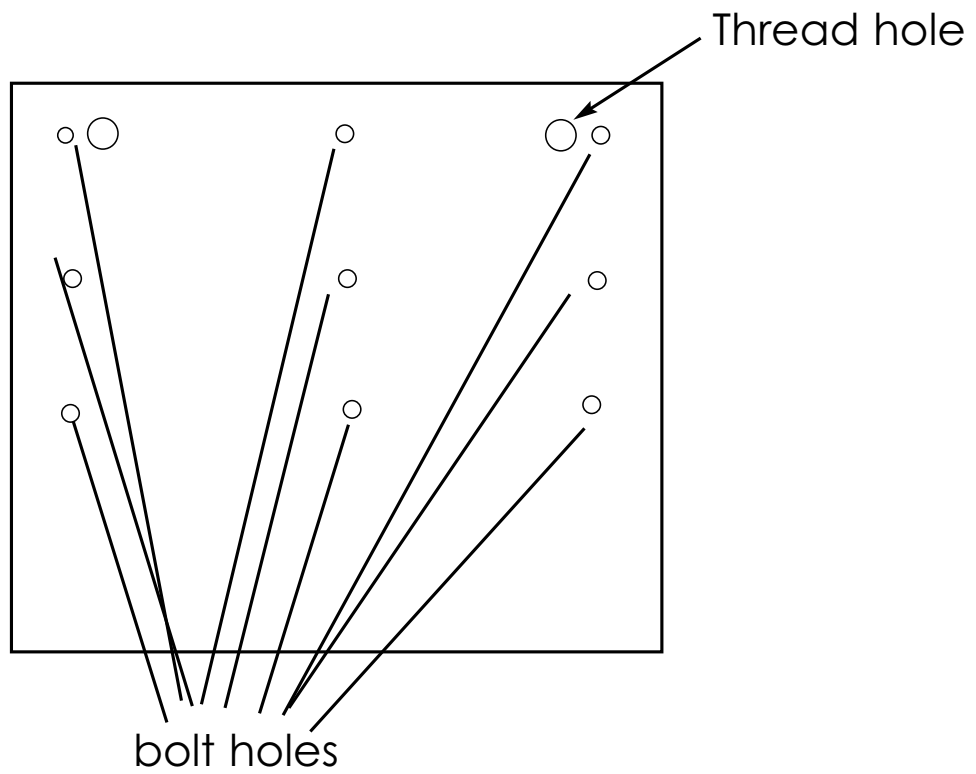

Top of reservoir

Place the still on top of the reservoir and line up the two front holes as these are the only ones you can see.

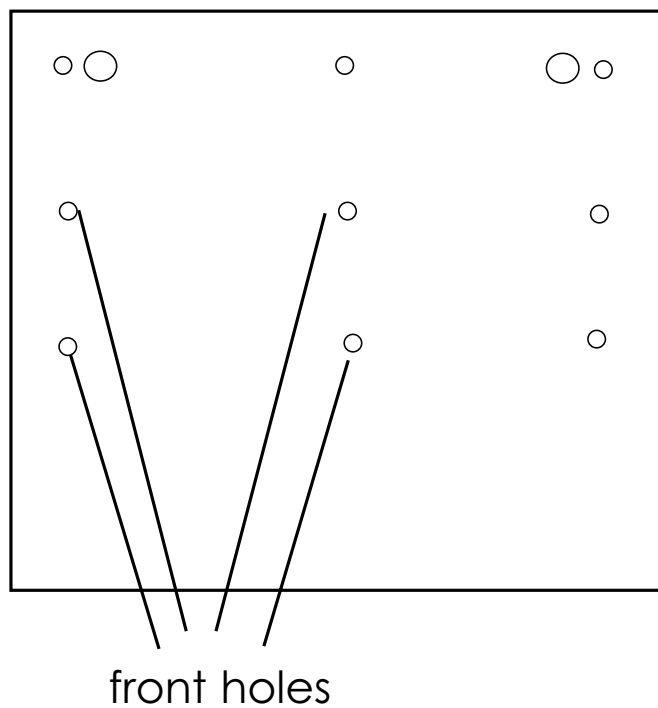

Turn the reservoir around so you are looking at the back. Undo the panel on the reservoir by unscrewing the 4 screws.

Inside you see the tank with a polystyrene lid. Underneath the tank you will see two fittings please undo these and remove the tank, Remove the lid after the tank has come out as it is easier. In the process of removing the tank you will see the float switch is attached, just unplug it, and leave to one side.

Now with the reservoir empty you can now attach the still with four bolts leaving two left.

When this is done undo the electrical panel by removing the 2 screws.

When looking, in the corners you will see two more holes and these are for your last two bolts, Please do not use the thread hole.

The plug and wire you have just seen with the female connector please pull through the thread hole with the plug inside the reservoir and place the cable tie round it so that it does not fall through. Use the red connectors on the end of the wire for an easy and safe connection.

Please refer to Circuit board diagram.

The pressure switch, please disconnect and place the connectors you have just made on these terminals. Your pressure switch does not work now, remove if you wish to.

With the female plug please connect to the plug on tank.

To test that it works place the panel back onto the cabinet and plug in the mains leads, **Please ensure the heaters are not attached**. Turn the cabinet on and turn both units on, take the float inside the cabinet and turn upside down so the heater lights come on. Pull the float switch up inside the tank and the reservoir light will come on knocking the heaters out. To reset turn all off and start again.

After the test you have to put everything back.

Put the polystyrene lid in first with the pipe threaded through the top, then the tank will slide in underneath, reattach the connections underneath the tank, Make sure that they are secure and they also have the black washers inside.

Place the panel back with the 4 screws.

Turn back round and place the boilers, heaters and condensers back into the cabinet.

One more thing before you start you will notice you have a piece of tubing hanging from the reservoir this is to be connected to the output nozzle on the cabinet.

WSS/4 - WSS/8

What you should have

1. METAL STAND for free standing or wall mounting, complete with BOILING FLASK fitted with HEATER
2. CONDENSER, coil type
3. SYPHON TUBE
4. CONSTANT LEVEL

Please refer to diagram

- Taking the condenser, fit into the neck of the boiling chamber so that the rubber rings on the condenser form a steam-tight seal between the two parts.
- Place the syphon tube into the 28mm cap on the top side of the boiling chamber.
- Place the constant level into the 28mm cap on the side of the boiling chamber
- Connect water mains (by means of rubber or plastic tubing) on to the plastic nozzle at the base of the condenser (Nozzle 2), which is connected to the coil inside.
- Nozzle 1 already has tubing fitted this is to be placed inside the constant level
- You will find another plastic nozzle at the base of the condenser (Nozzle 3). This is where the distillate comes out when the Still is in operation.
- Connect the rubber or plastic tubing to this nozzle and into a container (e.g. Reagent bottle). The nozzle outlet on the constant level device is to waste, so link with a tube to the sink or drain.

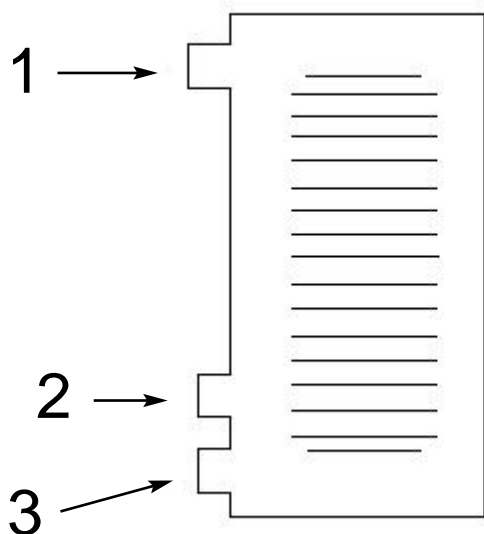

Condenser for WSS/4 and WSS/8

DEIONISERS

Piping internally

Please refer to diagram of the cabinet and the condenser.

The Numbers correspond with the holes shown on the diagram

1. Deioniser supply (connected to the float switch)
2. Waste to nozzle 2 on Unit 1 condenser
3. Output to nozzle 3 on both condensers
(WSC/4D or AWC/4D nozzle 3 on Unit 2's condenser only)
4. PS is the pressure switch.
5. Main water supply to nozzle 1 on both condensers
6. Waste to nozzle 2 on Unit 2's condenser
7. Drain from Unit 1's boiler
8. Waste from Unit 1's boiler
9. Drain from Unit 2's boiler
10. Drain from Unit 2's boiler

EXTERNAL PIPING for all stills

The Numbers correspond with the holes shown on the cabinet diagram Hole No.

1. Connect the water supply from deioniser marked (DEIONISER SUPPLY).
The connections from the mains must be secure.
3. Connect hose from OUTLET to Reservoir.
Connect hose from all WASTE to external Drainage area (holes 2,6,8,and 10)
4. Connect a hose to nozzle marked PS to the reservoir
5. Connect tubing to your main water supply and this is not going through the deioniser

Holes 7 and 9 are drainage holes, connect hose and run to drain when you want to empty the boiling chamber

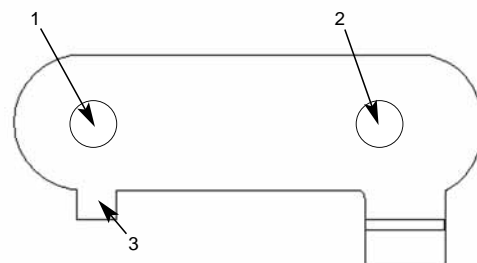
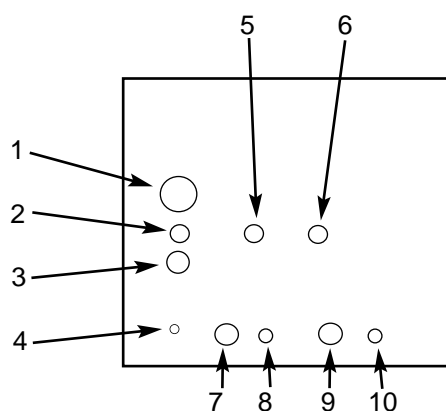

The cabinet

CONDENSER (nozzle 1, 2 and 3)

The **deionisers** come with separate instructions which are in the box which they are supplied in, they are very simple to use and the instructions are very straight forward.

Trouble Shooting

1. If boiler is not filling up please check.
 - i) Water Supply
 - ii) Is the Drainage tap closed
 - iii) Are all the seals on boiler tight with cap & washer
 - iv) Is there any cracks or breakage in the glass.
2. If a lot of steam is being produced ensure the heating element is covered with water. Increase flow of water supply. Control of the cooling water will effect volume of distillate. More cooling water does not always produce more distillate.
3. In the event that the sensor cuts the still off, for whatever reason, being a bi-metal sensor needs time to reset, so a delay in switching the still off and back on again to re-start distillate production should be observed. These sensors will only operate in the event of a boil dry situation. Normal water failure would bring into operation the float switch, therefore the sensor would only come into operation in the event of boiler breakage and loss of water.
4. If the still is completely dead with no mains supply, check the fuses in the plug, also Panel fuse and Circuit board fuses.
5. If main supply is working and float switch is not working it is either 4 things:
 - 1) The Float switch
 - 2) Solenoid valve (Aquamatic)
 - 3) Pressure switch (Aquamatic)
 - 4) Fuses on Circuit board and also check Fuses on Panel face.



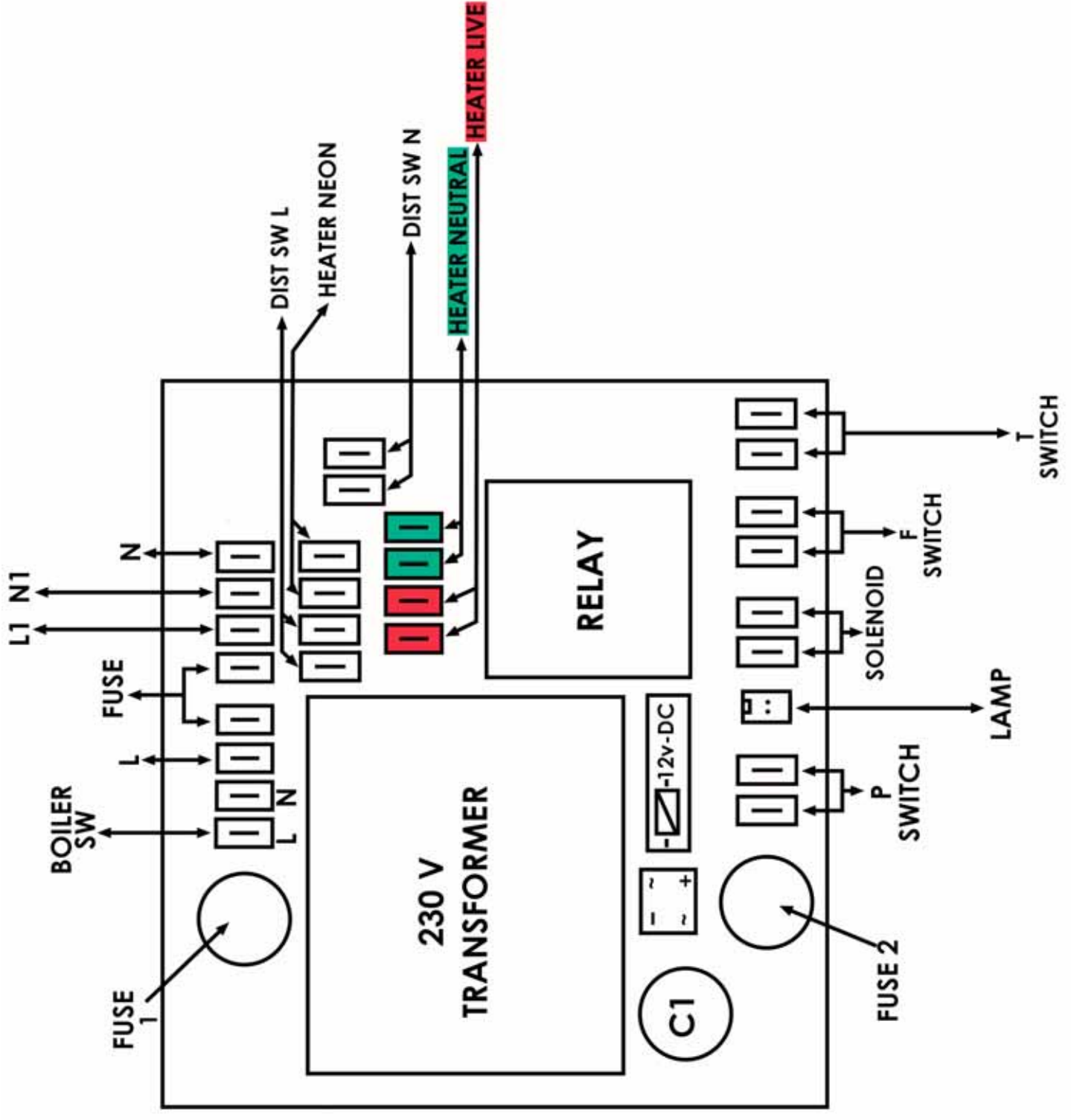

SPARES AVAILABLE

UPRIGHT STILLS

WSS/48	4 Ltr ROUND BOILER
WSS/88	8 Ltr ROUND BOILER
WSS/4S	STAND FOR WSS/4 & WAS/8
WSS/4C	CONDENSER 4 Ltr
WSS/8C	CONDENSER 8 Ltr
48C	3 Kw HEATER FOR 4 Ltr & 8 Ltr

CIRCUIT BOARDS

CB4	For WSC/4	Water Still
CB8	For WSC/8	Water Still
CB44	For AWC/4	Water Still
CB88	For AWC/8	Water Still
CB4S	For WSC/4S	Water Still
CB8S	For WSC/8S	Water Still
CB44S	For AWC/4S	Water Still
CB88S	For AWC/8S	Water Still
CBES	For WSE/4S	Water Still

WATER STILL

4BS	BOILER FOR SILICA HEATER
4BC	BOILER FOR METAL HEATER
4ST	SCREWCAP FOR SILICA HEATER
4WW	WASHER FOR SILICA HEATER
4TT	SENSOR HOLDER
4CC	CONDENSER
4CL	CONSTANT LEVEL FOR ALL BOILERS
W42C	SCREWCAP FOR CONDENSER
WPC	PERSPEX COVER
4PS	PLAIN SYPHON TUBE
4GW	CLAMP INSERT & P.T.F.E. WASHER FOR METAL HEATERS
WT3	SET OF PLASTIC CAPS, NOZZLES & WASHERS (8 Ltr)
WT1	SET OF PLASTIC TUBING CAPS, NOZZLES & WASHERS (4Ltr)
4C18	SET OF CAPS & NOZZLES FOR CONDENSER
WT2	10 METRES TUBING FOR MAINS WATER & WASTE

ELECTRICAL

WJP	PANEL SOCKET & PLUG (Pair)
WAG	INDICATORS (AMBER & GREEN)
WFH	PANEL FUSE HOLDER
WS	ROCKER SWITCH
WCG	CABLE GLANDS
WER	RELAY
WET	TRANSFORMER
WERC	RECTIFIER
WCB	TERMINAL BLOCKS
WF	13 AMP FUSE (Pack of 5)
WSP	AIR PRESSURE SWITCH (AQUA-MATIC)
WRS	REED SWITCH FOR RESERVOIR
WPR	PLUGS (PAIR) FOR RESERVOIR CONNECTION
4HC	METAL HEATER
4SC	SILICA HEATERS 1.5 Kw
4SC2	SILICA HEATERS 1.25 Kw
GLSC	GLASS COVER FOR SILICA HEATER
4TS	SENSOR
4FS	FLOAT SWITCH WITH GLASSWARE
4SV	SOLANOID VALVE
4WAR	RESERVOIR FULL INDICATOR
4FW	200 M/AMP FUSE FOR TRANSFORMER
4PL	13 AMP PLUG & LEAD
4P6	FEMALE SOCKET 6-WAY AQUAMATICS
4P7	MALE PLUG 6-WAY AQUAMATICS

Recommended Cleaning Instructions for **Hamilton Water Stills**

Always clean on a regular basis depending on the quality of mains water where the still is situated.

DO NOT WAIT UNTIL THE BUILD UP OF SEDIMENTS IS TOO GREAT AS THIS COULD MEAN DISMANTLING THE STILL.

If cleaning is done on a regular basis it becomes a very simple exercise. We do not recommend the use of acids because of damage to heating elements. We recommend domestic Kettle descaler, whatever brand is available locally to each customer. The customer should follow the manufacturers instructions as near as possible.

Anyone using distilled water should be aware of the need to keep the water still clean and act sooner rather than later. Later can mean contaminated distillate and breakage to glassware through high build up of solids in the boiling chamber.

To apply the cleaner to our range of water stills can be done through the constant level, or the censer inlet or in the case of vertical condensers, the condenser can be removed. Drainage and flushing can be done through the plastic drain stopcock.

Note: Ensure that the drain stopcock is closed again before resuming distillate production.